



RIG# 62

SST ENERGY CORPORATION

PREP DM1 1800 A/C

SPECIFICATIONS

Drawworks	<i>PREP DM1-1800 with 1-3/8" line</i>
Drawworks horsepower	<i>1800 hp</i>
Hoisting Capacity	<i>750,000 lbs.</i>
Pumps	<i>2 X F-1600; 1600hp</i>
Pump pressure	<i>7500 psi</i>
Mobility	<i>Skidding- up to 150'</i>
Engines	<i>3 X Cummins QSK-50 1,100 KW Tier II</i>
Controls	<i>Omron VFD</i>
Top Drive	<i>Canrig 500 ton</i>
Floor automation	<i>ST-80 and Auto Catwalk</i>
Mast	<i>IDM 750,000lbs on 12 lines</i>
Substructure	<i>Clear height 18' 8"; Floor Height 23' 6"</i>
Rotary table	<i>27.5"</i>
Mud system	<i>1200 bbl.</i>
Shale shakers	<i>3 Brandt King Cobra Venom</i>
Solids Control	<i>Two cone desander and 16 cone desilter</i>
BOP Equipment	<i>As Requested</i>
Accumulator	<i>6 station -18 (15 gallon) Bottles</i>
Choke Manifold	<i>10,000 psi</i>
Gas Buster	<i>Yes</i>
Boiler	<i>150 hp</i>
Fuel	<i>21,000 gallons</i>
Water	<i>500 bbl.</i>

***Modifications available as required**

Rig 62 Building Spacing Drawing

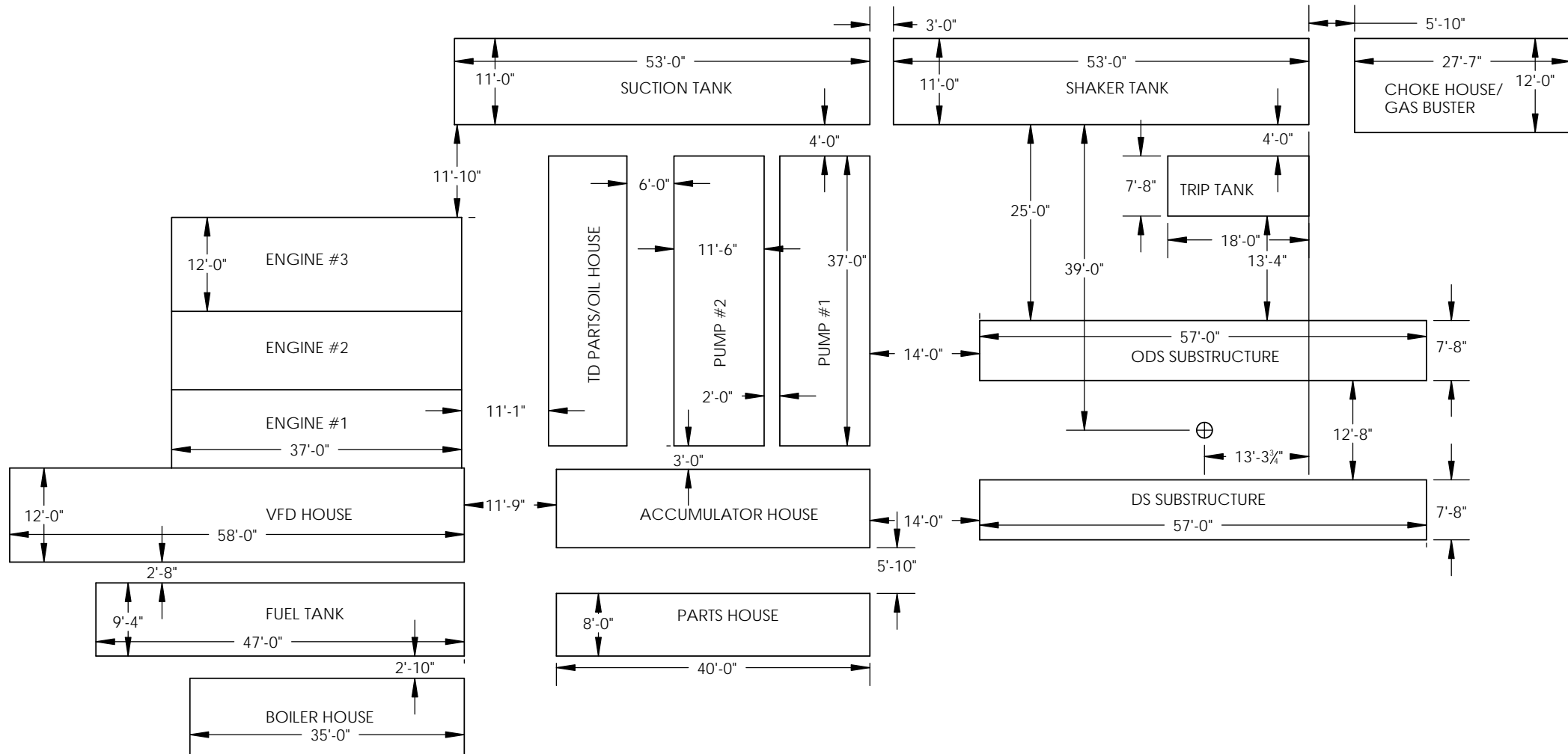

NOTE: ALL MEASUREMENTS ARE WALL-TO-WALL.
 10'-0" BUILDING WIDTH UNLESS OTHERWISE NOTED.
 ASSUME 18" LOADING HITCHES ON NARROW ENDS.

Rig 62 Location & Dryholes Drawing

DRYHOLE DIMENSIONS

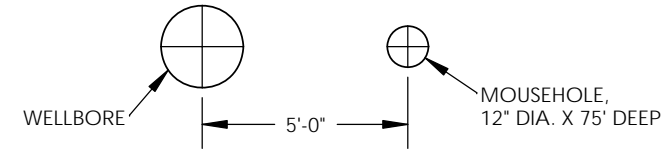

MINIMUM LOCATION DIMENSIONS

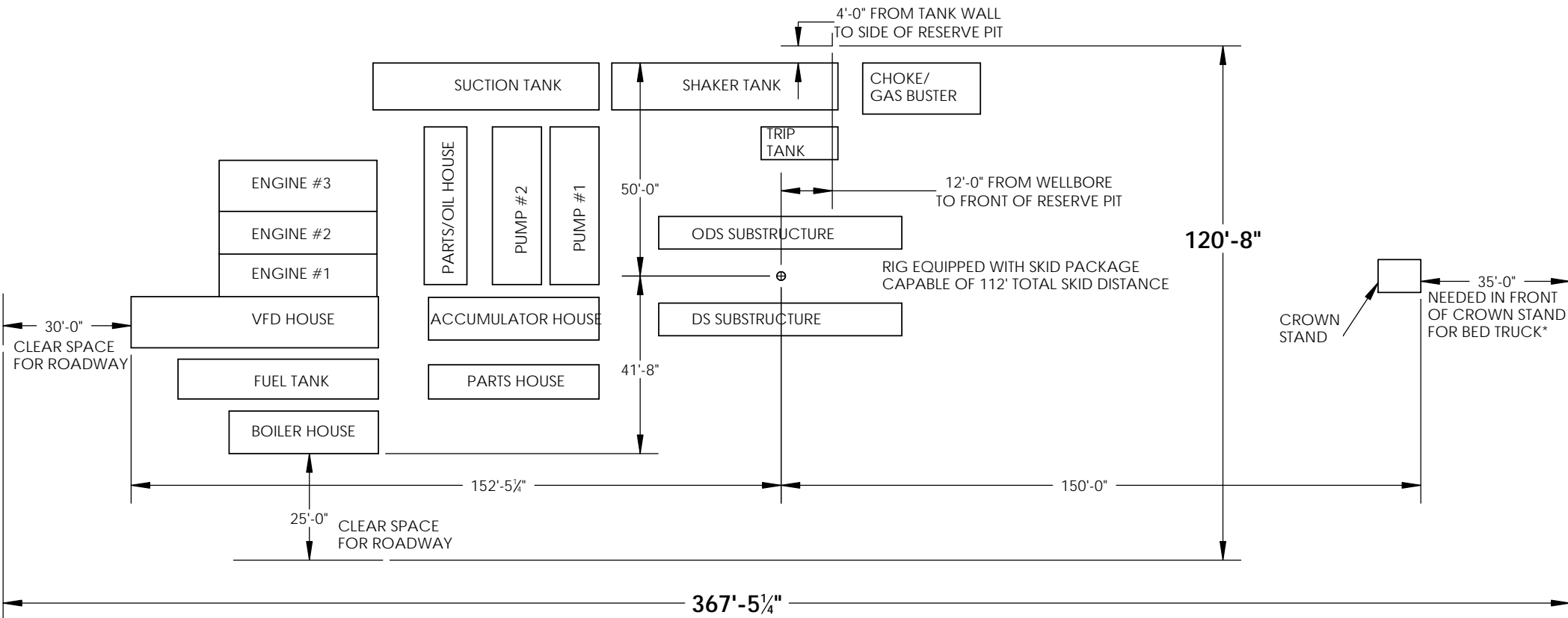

* 185'-0" CLEAR SPACE NEEDED IN FRONT OF FURTHEST WELL IF ON MULTI-WELL PAD